

### Controller for I-V meter display & CPU-cooler fan part

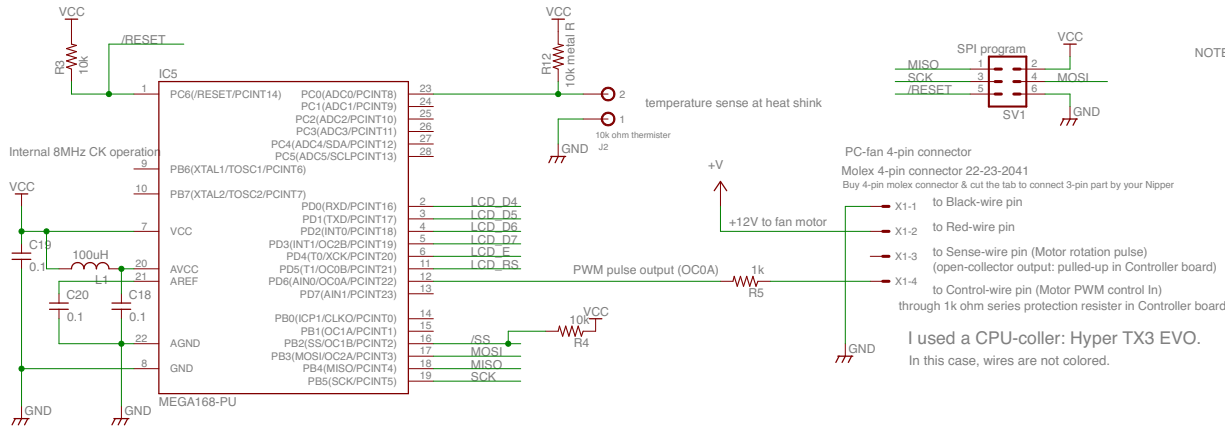

NOTE: When using WinStar OLED, LCD\_E line should be terminated by R13=470 ohm at OLED side to stabilize the operation

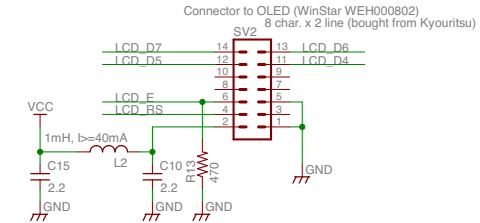

### OLED display part

### 0V ~ 24V 4A series regulator with current limit part

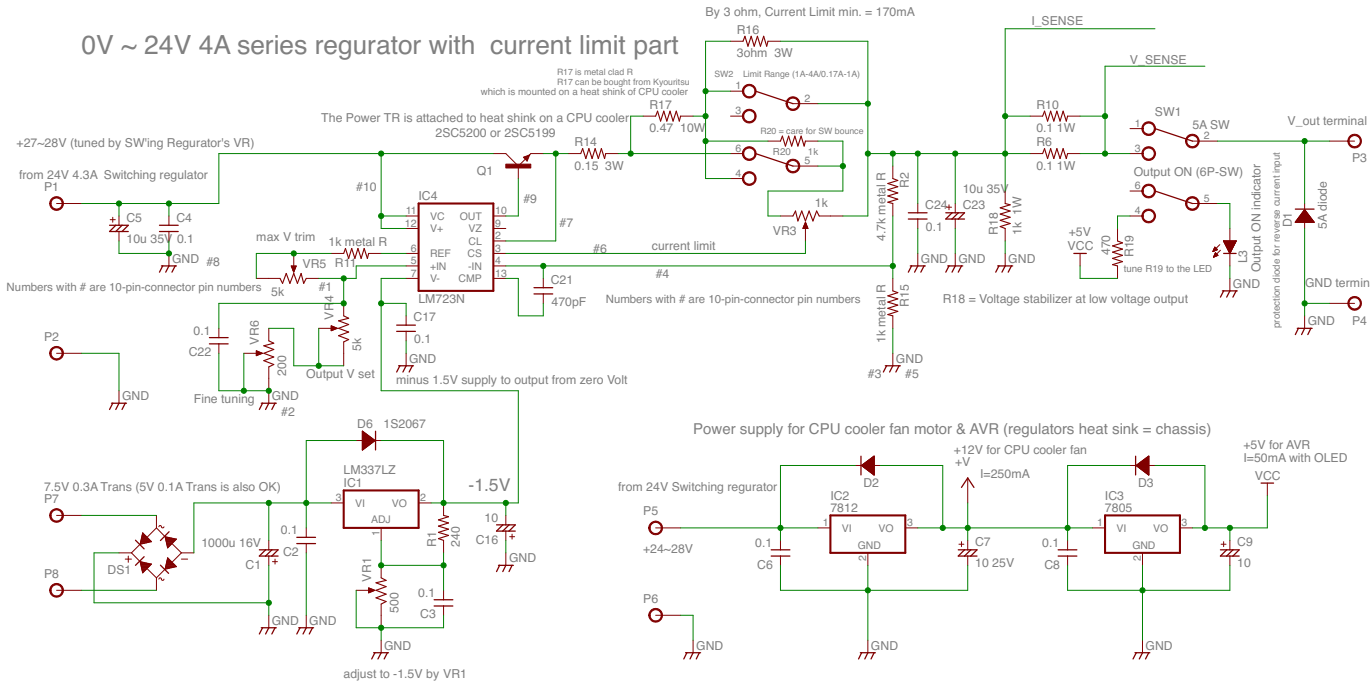

### I-V sensing part

